

PARTS LIST

MODEL T-89

TANNER SYSTEMS COMPACT DISPENSER



P.O. BOX 488, ST JOSEPH, MN 56374
 PHONE: (320) 363-1800
 TOLL-FREE: (800) 461-6454
 FAX: (320) 363-1812

www.tannersystems.com
 info@tannersystems.com

IMPORTANT...please order parts through one of our distributors.

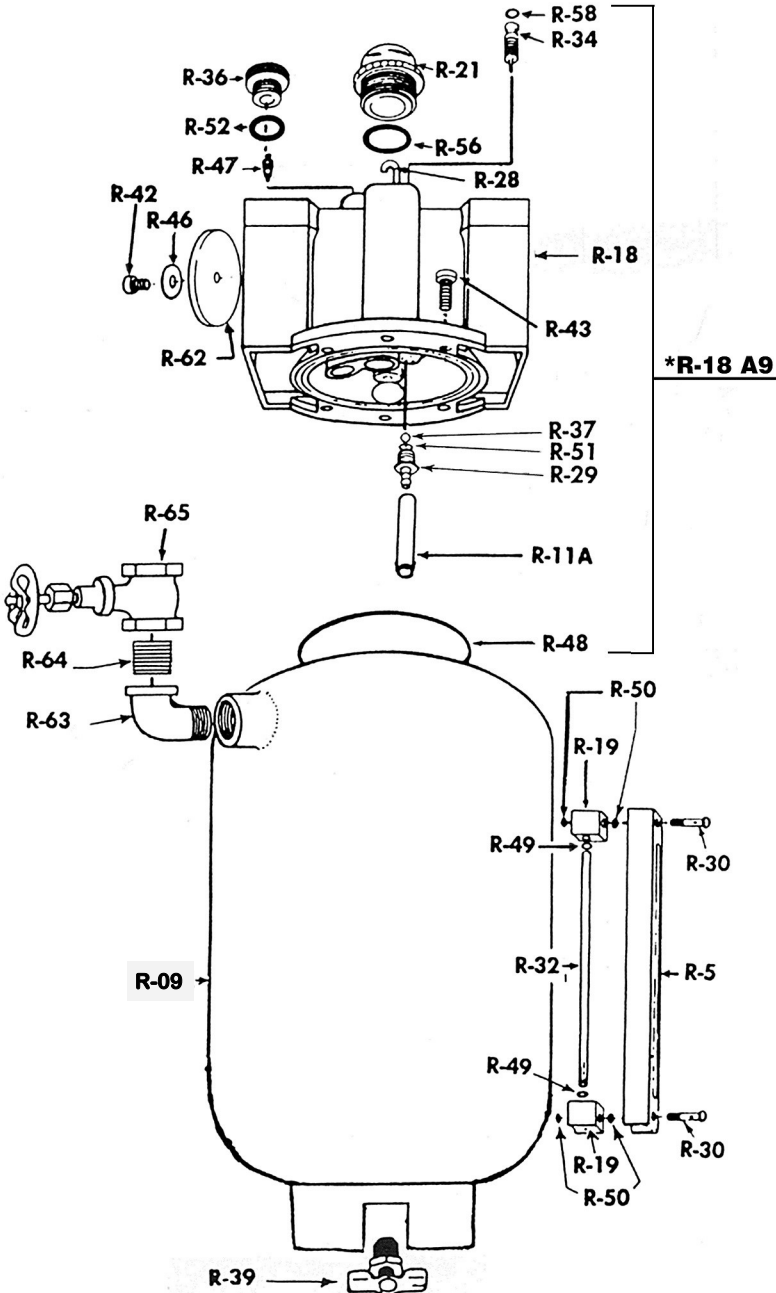

-WARNING-
MAX. WORKING PRESSURE: 200 p.s.i.
MAX. INTERNAL AIR TEMP: 150° F

PART NO.	ITEM
R-58	O'Ring
R-34	Adjusting Screw
R-21	Sight Dome
R-56	O'Ring
R-36	Vent/Bleed Plug
R-52	O'Ring
R-47	Check Valve
R-43	Screw (6)
R-18	Body w/2" inlet, outlet
R-28	Feed Tube
R-42	Flow Guide Screw
R-46	Flow Guide Washer
R-62	Flow Guide
R-37	Ball Check
R-51	O'Ring
R-29	Adapter
R-11A	Siphon Tube
R-48	Gasket
R-50	O'Ring (4)
R-19	Gauge Glass Block (2)
R-49	O'Ring (2)
R-32	Gauge Glass
R-30	Screw (2)
R-05	Guard
R-09	Bowl, 5 Gal., (NA)
R-63	1" St. Ell
R-64	1" x Cl. Nipple
R-65	1" Gate Valve
R-39	Drain Cock
R-25	Repair Kit (Not included With De-Icer) Consists of: 2 ea. R-58, R-49; 1 ea. R-34, R-21, R-56, R-52, R-47, R-42, R-46, R-62, R-37, R-51, R-29, R-48; 4 ea. R-50
*R-18 A9	Body Assembly

TANNER® SYSTEMS COMPACT DISPENSER MODEL T-89

INSTALLATION, FILLING AND OPERATING INSTRUCTIONS

1. Install Dispenser as close as possible to the problem area. Air must be less than 150°F at installation point.
2. If there is more than one freezing problem, install Dispenser at a point beyond the first receiver where all out-going air lines will be treated. ONLY install before the first receiver if absolutely necessary to reach all problem areas.
3. **DO NOT** support the Dispenser by the hoses or pipe alone; the weight and movement could cause damage or cracking to the Body of the Dispenser. Install the Dispenser with air flowing in the direction indicated by the arrow on the Body, R-18A9.
4. Use only TANNERGAS®, FREEZE-BAN or NO-TOX2® fluid in this Dispenser. **DO NOT SMOKE WHILE FILLING.** This Dispenser may be filled under pressure by removing the Fill Plug, R-36, and pouring the fluid into the Bowl through the Fill Plug opening. NOTE: As the Fill Plug is removed, the air pressure in the Bowl is released; bleed air SLOWLY to prevent Fill Plug from disengaging under pressure. Be certain that air is completely bled before removing the Fill Plug. When filling is complete, re-install Fill Plug.
5. Allow Bowl to fill with air. The rate of fluid delivery, TANNERGAS®, FREEZE-BAN or NO-TOX2®, may be controlled by turning the Adjusting Screw, R-34, counter clockwise for more, and clockwise for less, until desired fluid is dripping through Sight Dome, R-21. Do not open Adjusting Screw more than two turns. CAUTION: Do not remove Adjusting Screw when De-Icer is under pressure; be certain to make adjustment while there is MAXIMUM air movement through the Body. The fluid delivery rate will change automatically to deliver more during higher air flows and less for air flows lower than the original setting.

MAINTENANCE

1. When TANNERGAS®, FREEZE-BAN or NO-TOX2® is not needed, close the Adjusting Screw, R-34. Over-tightening may damage Adjusting Screw and/or Body.
2. If contaminants are in the Bowl, R-09, collect on the Siphon Tube, R-11A, or the inlet filter, wash with mild solvent or soaps.
3. Drain off any contaminants which collect in the bottom of the Bowl, using Drain Cock, R-39. Relieve pressure in Bowl prior to opening Drain Cock by slowly opening Fill Plug, R-36 (refer to above step 4).
4. Should it be necessary to disassemble this Dispenser for cleaning or repair, we recommend the Repair Kit, R-25, which contains all the O'Rings and other small replacement parts.

WARRANTY

SELLER DISCLAIMS ANY AND ALL WARRANTIES UNLESS THIS DISPENSER IS USED EXCLUSIVELY WITH TANNERGAS®, FREEZE-BAN OR NOTOX2® AND ALL INSTRUCTIONS REGARDING INSTALLATION AND USE HAVE BEEN FOLLOWED.



P.O. BOX 488, ST JOSEPH, MN 56374

PHONE: (320) 363-1800
TOLL-FREE: (800) 461-6454
FAX: (320) 363-1812

www.tannersystems.com
info@tannersystems.com

Printed in U.S.A.
06/23