

MODEL T-89

TANNER DE-ICER



P.O. BOX 488, ST JOSEPH, MN 56374

PHONE: (320) 363-1800

TOLL-FREE: (800) 461-6454

FAX: (320) 363-1812

www.tannersystems.com
 info@tannersystems.com

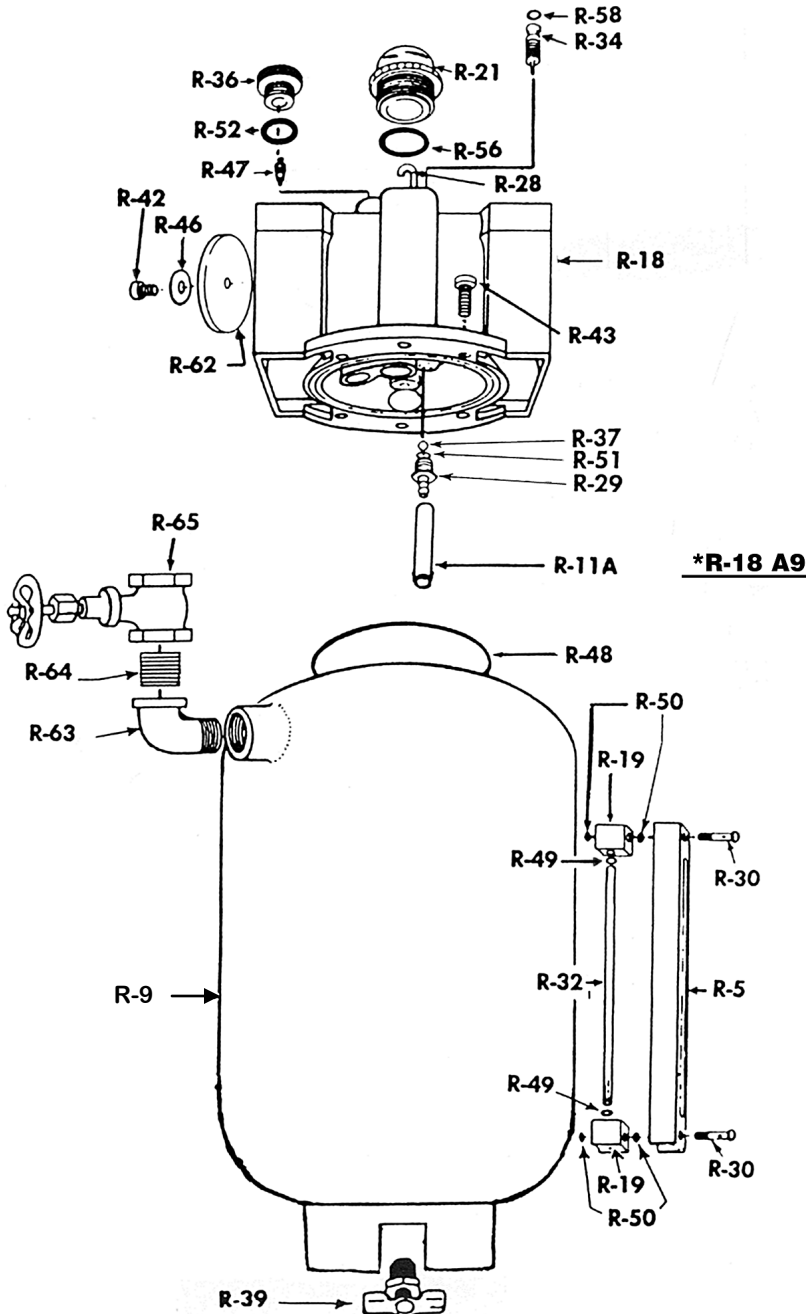

**IMPORTANT...please order parts through
 one of our distributors.**

PART NO.	ITEM
R-58	O'Ring
R-34	Adjusting Screw
R-21	Sight Dome
R-56	O'Ring
R-36	Vent/Bleed Plug
R-52	O'Ring
R-47	Check Valve
R-43	Screw (6)
R-18	Body w/2" inlet, outlet
R-28	Feed Tube
R-42	Flow Guide Screw
R-46	Flow Guide Washer
R-62	Flow Guide
R-37	Ball Check
R-51	O'Ring
R-29	Adapter
R-11A	Siphon Tube
R-48	Gasket
R-50	O'Ring (4)
R-19	Gauge Glass Block (2)
R-49	O'Ring (2)
R-32	Gauge Glass
R-30	Screw (2)
R-5	Guard
R-9	Bowl, 5 Gal., (NA)
R-63	1" St. Ell
R-64	1" x Cl. Nipple
R-65	1" Gate Valve
R-39	Drain Cock
R-25	Repair Kit (Not included With De-Icer) <i>Consists of: 2 ea. R-58, R-49; 1 ea. R-34, R-21, R-56, R-52, R-47, R-42, R-46, R-62, R-37, R-51, R-29, R-48; 4 ea. R-50</i>
*R-18 A9	Body Assembly

-WARNING-
MAX. WORKING PRESSURE: 200 p.s.i.
MAX. INTERNAL AIR TEMP: 150° F

TANNER DE-ICER

MODEL T-89

INSTALLATION, FILLING AND OPERATING INSTRUCTIONS

1. Install De-Icer as close as possible to the problem area. Air must be less than 150°F at installation point.
2. If there is more than one freezing problem, install De-Icer at a point beyond the first receiver where all out-going air lines will be treated. NEVER install before the first receiver.
3. **DO NOT** support the De-Icer by the hoses or pipe alone; the weight and movement could cause damage or cracking to the Body of the De-Icer. Install the De-Icer with air flowing in the direction indicated by the arrow on the Body, R-18.
4. Use only TANNERGAS[®], FREEZE-BAN or NO-TOX2[®] fluid in this unit. **DO NOT SMOKE WHILE FILLING.** This De-Icer may be filled under pressure by the following procedures:
 - a. Bleed air from tank through Vent/Bleed Plug, R-36. Bleed air SLOWLY to prevent Vent/Bleed Plug from disengaging under pressure.
 - b. Open 1" Gate Valve, R-65, SLOWLY, and fill with fluid.
 - c. Close 1" Gate Valve and replace bleed Fill Plug tightly.
5. Allow several minutes for Bowl to fill with air. The rate of fluid delivery, TANNERGAS[®], FREEZE-BAN or NO-TOX2[®], may be controlled by turning the Adjusting Screw, R-34, counter clockwise for more, and clockwise for less, until desired fluid is dripping through Sight Dome, R-21. Do not open Adjusting Screw more than two turns.
CAUTION: Do not remove Adjusting Screw when De-Icer is under pressure; be certain to adjust while there is air movement through the Body. This De-Icer delivers all the fluid downstream that passes through the Sight Dome. The fluid delivery rate will change automatically to deliver more during higher air flows and less for air flows lower than the original setting.

MAINTENANCE

1. When TANNERGAS[®], FREEZE-BAN or NO-TOX2[®] is not needed, close the Adjusting Screw, R-34; over-tightening may damage Adjusting Screw seat.
2. If contaminants in the Bowl, R-9, collect on the Siphon Tube, R-11A, inlet filter, wash the filter in solvent.
3. Drain off any contaminants which collect in the bottom of the Bowl, using Drain Cock, R-39. Relieve pressure in Bowl prior to opening Drain Cock by slowly opening Vent/Bleed Plug, R-36 (refer to above step 4).
4. Should it be necessary to disassemble this De-Icer for cleaning or repair, we recommend the Repair Kit, R-25, which contains all the O'Rings and other small replacement parts.

WARRANTY

SELLER DISCLAIMS ANY AND ALL WARRANTIES UNLESS THIS DE-ICER IS USED EXCLUSIVELY WITH TANNERGAS[®], FREEZE-BAN OR NOTOX2[®] AND ALL INSTRUCTIONS REGARDING INSTALLATION AND USE HAVE BEEN FOLLOWED.



P.O. BOX 488, ST JOSEPH, MN 56374

PHONE: (320) 363-1800
TOLL-FREE: (800) 461-6454
FAX: (320) 363-1812

www.tannersystems.com
info@tannersystems.com